



# *Rocky Mountain Metals, Inc*

Manufacturer of Standard and Custom Hollow  
Metal Doors, Frames and Windows

# Index

<b>Introduction</b>	3
<b>List of References</b>	
Educational	4-5
Medical Care	6
Municipal, Military and Governmental	7
Corporate, Retail and Commercial	8
Hotels	9
Libraries and Casinos	10
<b>Hollow Metal Doors</b>	
General Information	11
Door Details	12
1100 Polystyrene Core	13
1200 Steel Stiffened	14
1500 Lead Lined	14
1300 Temperature Rise	15
1600 Dutch Doors	16-17
<b>Hollow Metal Frames</b>	
General Information	18-19
Welded Frames	20
Knockdown (KD) Frames	21
Pocket Frames	22
Custom Frames	23
<b>Tornado Resistant Opening</b>	24
1400 FEMA Frame and Shutter	25-26
1400 FEMA Door and Shutter	27
<b>Leadership in Energy and Environmental Design</b>	28
<b>Contact Information</b>	29
<b>Buy America Act</b>	30
<b>Certifications</b>	30



Rocky Mountain Metals, Inc., is a manufacturer of Standard and Custom Hollow Metal Door and Frame Products located in Raton, New Mexico, just south of the Colorado border. Established in 1988, the company has over the years, supplied hollow metal products to numerous types of facilities from small offices and schools, to prestigious corporate headquarters, hospitals and exclusive hotels.

We offer excellent service with short lead times and very competitive prices. Customized and quick quoting as well as order processing through our knowledgeable and experienced staff. By the attached references, we hope that you get an understanding of not only our capabilities, but also that we are dependable and reliable. A partner you can count on.

Rocky Mountain Metals, Inc. is continually expanding capabilities, improving efficiencies and upgrading production facilities to meet today's high standards for quality and customer service. Our product program consists of among others:

#### Hollow Metal Frames

- Face and fully welded door and window frames. From standard frames to complex customized frame configurations. If you can design it, we can build it
- Lead lined door and window frames
- Knock down frames for welding and drywall applications
- Pocket frames

#### Hollow Metal Doors

- Polystyrene core construction
- Steel stiffened doors
- Lead lined doors
- Temperature rise doors
- Dutch doors

#### Openings Solutions

Classified to FEMA P-361 (2015) and certified to ICC 500 (2014)

Labeling and fire rating under the procedures from Underwriters Laboratory (UL). Rocky Mountain Metals, Inc. is authorized to label three-sided frames and doors for up to three hours and sidelights and windows for up to 90 minutes.

All our products qualify for full LEED Credits for recycled content MR.4.1 and 4.2, as they contain more than 25% recycled material as per the LEED Definitions (100% of Post Consumer and 50% of Pre Consumer Recycled Content).

We are a member of the **National Association of Architectural Metal Manufacturers (NAAMM)** and **Hollow Metal Manufacturers Association (HMMA)**. Our products are manufactured in accordance with the applicable **HMMA Standards** such as HMMA 802-07 "Manufacturing of Hollow Metal Doors and Frames" and HMMA 841-07 "Tolerances and Clearances for Commercial Hollow Metal Doors and Frames". Consequently, as per these standards, we meet and or exceed the applicable ANSI/SDI criteria.

We have an experienced management team in place with solid Hollow Metal background, as well as, experience from top level positions in the Door and Hardware Industry in the US and internationally.

Please take the time to review the information in this brochure to get a better understanding of our products and services we can provide. I hope that you will find this helpful enough to give us a chance to show what we can do for you in the areas of Standard and Custom Hollow Metal .

Sincerely yours,

Clas Thelin  
President  
[cthelin@rockymountainmetals.com](mailto:cthelin@rockymountainmetals.com)

# Rocky Mountain Metals, Inc. is the proud supplier of hollow metal doors, frames and/or windows for these projects

## Educational Facilities - Suitable solutions for any level

Over the years we have supplied doors and frames to educational facilities all over the country. From small basic school facilities to state of the art universities and colleges. Our product program is constantly under development to cater to the ever changing life safety needs in this area. Additionally, our products are frequently used where complex and highly customized hollow metal solutions are chosen.

- |   |                   |
|---|-------------------|
| Greenway High School                          | Phoenix, AZ       |
| Thunderbird High School                       | Phoenix, AZ       |
| Tramonto Ridgeline Academy                    | Phoenix, AZ       |
| Western School of Science and Technology      | Phoenix, AZ       |
| Mammoth Middle School                         | Mammoth Lakes, CA |
| San Diego State University                    | San Diego, CA     |
| Cherry Creek Middle School #11                | Aurora, CO        |
| Dakota Ridge State University                 | Littleton, CO     |
| American Academy                              | Parker, CO        |
| Dodge City High School USD 443                | Dodge City, KS    |
| Sunnyside Elementary School                   | Dodge City, KS    |
| Unified School District #443 Soule Elementary | Dodge City, KS    |
| Lincoln Elementary School                     | Hoisington, KS    |
| Andre Agassi College Prep Academy             | Las Vegas, NV     |
| Clifford J. Lawrence Jr. High                 | Las Vegas, NV     |
| Hollingsworth Elementary School               | Las Vegas, NV     |
| Linda Rankin Givens Elementary School         | Las Vegas, NV     |
| Palo Verde High School                        | Las Vegas, NV     |
| Petersen Elementary School                    | Las Vegas, NV     |
| Rancho High School                            | Las Vegas, NV     |
| UNLV Campus                                   | Las Vegas, NV     |
| Rio Grande High School                        | Albuquerque, NM   |
| University of New Mexico Farris Engineering   | Albuquerque, NM   |
| Fort Wingate Elementary School                | Fort Wingate, NM  |
| New Mexico State University Grants            | Grants, NM        |
| Hobbs Schools                                 | Hobbs, NM         |
| Santa Fe Indian School                        | Santa Fe, NM      |
| West Las Vegas Middle School                  | Las Vegas, NM     |
| Woodard Schools <b>(FEMA)</b>                 | Woodard, OK       |
- More Educational listings are on the next page!



**New Mexico State University Grants  
Grants, New Mexico**

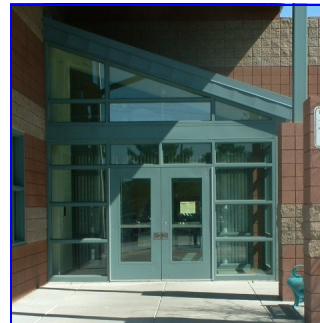

**Petersen Elementary School  
Las Vegas, NV**

**Rocky Mountain Metals, Inc. is the proud supplier of hollow metal doors, frames and/or windows for these projects**

**Educational Facilities - Suitable solutions for any level**

Over the years we have supplied doors and frames to educational facilities all over the country. From small basic school facilities to state of the art universities and colleges. Our product program is constantly under development to cater to the ever changing life safety needs in this area. Additionally, our products are frequently used where complex and highly customized hollow metal solutions are chosen.

- |   |                      |
|---|----------------------|
| University of Rhode Island-College of Pharmacy  | Kingston, RI         |
| Adrian Independent School District              | Adrian, TX           |
| Canyon Independent School District (FEMA)       | Amarillo, TX         |
| River Road Independent School District          | Amarillo, TX         |
| Antonian College Preparatory High School        | Castle Hills, TX     |
| JFK Elementary School                           | Corpus Christi, TX   |
| Lubbock Cooper Independent School District      | Cedar Park, TX       |
| George W. Truett Elementary School              | Dallas, TX           |
| Decatur Elementary School                       | Decatur, TX          |
| Dimmitt High School & Middle School             | Dimmitt, TX          |
| Everman Joe C Bean High School                  | Everman, TX          |
| TCU Annie Richardson Bass Building              | Fort Worth, TX       |
| Frenship New Elementary School                  | Wolfforth, TX        |
| Sam Houston Elementary School                   | La Feria, TX         |
| Georgetown High School                          | Georgetown, TX       |
| Texas Tech University—Architectural Bldg.       | Lubbock, TX          |
| Texas Tech University Horn Hall                 | Lubbock, TX          |
| Texas Tech University Sports Performance Center | Lubbock, TX          |
| Alice Ponder Elementary School                  | Mansfield, TX        |
| Brooks Wester Middle School                     | Mansfield, TX        |
| Glenn Harmon Elementary School                  | Mansfield, TX        |
| J L Boren Elementary School                     | Mansfield, TX        |
| Rogene Worley Middle School                     | Mansfield, TX        |
| Barbara Fasken Elementary School                | Midland, TX          |
| Bynum Schools                                   | Midland, TX          |
| Southwest Elementary School                     | Midland, TX          |
| Austin Elementary                               | San Angelo, TX       |
| Judith A. Resnik Elementary School              | San Antonio, TX      |
| Taylor Independent School District              | Taylor, TX           |
| Boulter Middle School                           | Tyler, TX            |
| Southwest Legacy High School                    | Von Ormy, TX         |
| North Elementary School                         | White Settlement, TX |



**Texas Christian University—Annie Richardson Bass Building—Fort Worth, TX**



**Texas Tech University Sports Performance Center Lubbock, TX**

**Rocky Mountain Metals, Inc. is the proud supplier of hollow metal doors, frames and/or windows for these projects**

**Medical Care Facilities - From clinics to full size hospitals**

The width of our products as well as our capability to supply anything from a simple door opening to custom hollow metal configurations of almost any size and complexity has made us a favored choice when it comes to medical care facilities. We can competitively supply products and solutions on all different levels, from a small clinic to full scale hospitals like the VA Hospital in Denver and Walter Reed Army Medical Center. This has gained us substantial expertise in the special products and needs in this area.

- |                                  |                 |
|----------------------------------|-----------------|
| Mayo Clinic                      | Scottsdale, AZ  |
| Banner Estrella Medical Center   | Phoenix, AZ     |
| Clovis Community Medical Center  | Clovis, CA      |
| Veterans Affairs Hospital        | Aurora, CO      |
| D.I. Medical and Research Center | Denver, CO      |
| Mercy Medical Life Safety        | Denver, CO      |
| Poudre Valley Hospital           | Denver, CO      |
| Greely Hospital                  | Greely, CO      |
| Sterling Medical Center          | Sterling, CO    |
| St. Catherine Cancer Center      | Garden City, KS |



**Georgetown Behavioral Health Institute  
Georgetown, TX**



**Walter Reed Medical Center  
Bethesda, MD**

- |  |                |
|--|----------------|
| Annapolis Health Clinic                        | Annapolis, MD  |
| Walter Reed Army Medical Center                | Bethesda, MD   |
| Walter Reed Behavioral Health Learning Center  | Bethesda, MD   |
| Henderson Hospital                             | Henderson, NV  |
| Mountain View Hospital                         | Las Vegas, NV  |
| Mountain View Regional Medical                 | Las Vegas, NV  |
| Sunrise Hospital                               | Las Vegas, NV  |
| UMC Trauma Center                              | Las Vegas, NV  |
| Behavioral Health Clinic                       | Fort Brigg, NC |
| Eufaula Indian Health <b>(FEMA)</b>            | Eufaula, OK    |
| Comanche County Memorial Hospital              | Lawton, OK     |
| Connors State Allied Health & Nursing Facility | Muskogee, OK   |
| Texas Rehabilitation Hospital                  | Arlington, TX  |
| Wolflin Medical Center                         | Amarillo, TX   |
| Matagonda Hospital                             | Bay City, TX   |
| Harmony Science Center                         | Cedar Park, TX |
| Presbyterian Hospital                          | Denton, TX     |
| Forest Park Medical Center                     | Fort Worth, TX |
| Mesa Springs Hospital                          | Fort Worth, TX |
| Sundance Psychiatric Hospital                  | Garland, TX    |
| Georgetown Behavioral Health Institute         | Georgetown, TX |
| Greystar Texas Medical Center                  | Laredo, TX     |
| Community Health Center                        | Lubbock, TX    |
| J Cleo Wellness Center                         | Ozona, TX      |
| CWC Health Science                             | Riverton, WY   |

# Rocky Mountain Metals, Inc. is the proud supplier of hollow metal doors, frames and/or windows for these projects

## Municipal, Military and Governmental Facilities - Security and Safety

In today's society security and safety are top priorities for most municipal, military and governmental facilities. We are proud of the confidence that our customers put on us and our ability to provide this for different openings and other hollow metal solutions. With a strong base in the Colorado, Texas and Nevada areas we have also been trusted to provide supply our products to other areas.

- |   |                         |
|---|-------------------------|
| Fort McClellan Army National Training Center <b>(FEMA)</b>    | Anniston, AL            |
| Davis-Monthan AFB-Aerospace Maintenance & Regeneration Group  | Davis-Monthan AFB, AZ   |
| F-35 Squadron Ops   | Luke AFB, AZ            |
| 4 <sup>th</sup> ID CAB Consolidated Battalion HQ              | Fort Carson, CO         |
| Chemical Science Building                                     | Tinker AFB, OK          |
| Company Operations Facility                                   | Fort Carson, CO         |
| Division Headquarters   | Fort Carson, CO         |
| Mountain View Ops   | Buckley AFB, Aurora, CO |
| Visiting Officers Quarters                                    | Peterson AFB, CO        |
| German Air Facility   | Holloman AFB, NM        |
| Taos County Administration and Detention                      | Taos, NM                |
| Cold Creek Prison   | Indian Springs, NV      |
| Clark County Detention Center                                 | Las Vegas, NV           |
| Federal Justice Tower   | Las Vegas, NV           |
| Juvenile Treatment Facility                                   | Las Vegas, NV           |
| Las Vegas Metropolitan Police Department                      | Las Vegas, NV           |
| Las Vegas Metropolitan Police Department – Fingerprint Bureau | Las Vegas, NV           |
| Regional Justice Center                                       | Las Vegas, NV           |
| Visiting Officers Quarters                                    | Nellis AFB, NV          |
| Lovelock Prison   | Lovelock, NV            |
| McKinley County Justice Complex                               | Gallup, NM              |
| National Security and Science Building                        | Los Alamos, NM          |
| Visiting Officers Quarters                                    | Altus AFB, OK           |
| Sheppard Air Force Base                                       | Norman, OK              |
| USPS Distribution Center                                      | Portland, OR            |
| Abilene Zoo   | Abilene, TX             |
| Visiting Officers Quarters                                    | Dyess AFB, TX           |
| DFW Airport Terminal E  | Dallas Ft. Worth, TX    |
| West Memorial Place   | Houston, TX             |
| Midland Municipal Courts                                      | Midland, TX             |
| Bexar Metro 911 Call Center <b>(FEMA)</b>                     | San Antonio, TX         |
| MCESD #8 Fire Station <b>(FEMA)</b>                           | Spring, TX              |
| P-251 Training Facility & Hangar Naval Air Station            | Whidbey Island, WA      |
| Army Aviation   | Warren AFB, Wyoming     |



**Clark County Detention Center  
Las Vegas, NV**

**Federal Justice  
Tower  
Las Vegas, NV**



# Rocky Mountain Metals, Inc. is the proud supplier of hollow metal doors, frames and/or windows for these projects

## Corporate, Retail and Commercial Buildings - Image and cost efficiency

When it comes to corporate, retail and commercial buildings the top priorities are most often image and cost efficiency. You want to be able communicate strength and success but at the same keep things under pretty tight cost control. We have been trusted to support in these efforts by a number of very successful companies.

- |                                      |                    |
|--------------------------------------|--------------------|
| Intel Headquarters – Water Plant     | Albuquerque, NM    |
| Rush Truck Center                    | Commerce, CO       |
| Village at the Peaks                 | Longmont, CO       |
| ABC Studios                          | New York, NY       |
| Ocean Spray III                      | Henderson, NV      |
| Bonnie Lane Senior Housing           | Las Vegas, NV      |
| Hilton Executive Offices             | Las Vegas, NV      |
| Switch Super NAP 8 Data Center       | Las Vegas, NV      |
| Veer Towers at City Center           | Las Vegas, NV      |
| Mesa Microlab                        | Albuquerque, NM    |
| Weapons Integration Facility         | Los Alamos, NM     |
| National Cowboy Hall of Fame         | Oklahoma City, OK  |
| Harley Davidson                      | Dallas, TX         |
| KPMG Plaza at Hall Arts              | Dallas, TX         |
| Chase Building                       | Farmers Branch, TX |
| Alcon Labs                           | Fort Worth, TX     |
| Facebook Data Center <b>(FEMA)</b>   | Fort Worth, TX     |
| Pier One Headquarters                | Fort Worth, TX     |
| Merrick Pet Foods                    | Hereford, TX       |
| Energy Plaza                         | Houston, TX        |
| West Memorial Place                  | Houston, TX        |
| Cabela's                             | Lubbock, TX        |
| XTO Energy Office                    | Midland, TX        |
| Helmerich & Payne Facility Expansion | Odessa, TX         |



**Switch SuperNAP 8  
Las Vegas, NV**



**West Memorial Place  
Houston, TX**



**Rocky Mountain Metals, Inc. is the proud supplier of hollow metal doors, frames and/or windows for these projects**

**Hotels - Hospitality and comfort coupled with safety and security**

With Nevada and Texas as a base, we are a trusted supplier to the hospitality industry. We have a proven track record to be able to support our customers need to provide a high level of comfort but at the same time not compromise the safety and security for their guests. Our products show up in a number of very prestigious facilities and also in more cost conscious environments.

Hyatt  
Ritz Carlton  
Adam's Mark Hotel  
Vail Marriott  
The Miami Beach EDITION Hotel  
Embassy Suites  
Hampton Inn  
Howard Hughes Parkway  
Mirage Hotel Theater Center  
Polo Twin Towers  
Hilton Garden Inn  
Winstar Hotel and Casino  
Marriott North  
Marriott South  
Marriott  
Hilton Garden Inn  
Marriott  
Townplace Suites

Sedona, AZ  
San Francisco, CA  
Denver, CO  
Vail, CO  
Miami, FL  
Las Vegas, NV  
Las Vegas, NV  
Las Vegas, NV  
Las Vegas, NV  
Las Vegas, NV  
Oklahoma City, OK  
Thackerville, OK  
Austin, TX  
Austin, TX  
Ft. Worth, TX  
Lubbock, TX  
Plano, TX  
Vernal, UT



**The Miami Beach EDITION Hotel  
Miami, FL**



**Hyatt  
Sedona, AZ**



**Ritz Carlton  
San Francisco, CA**

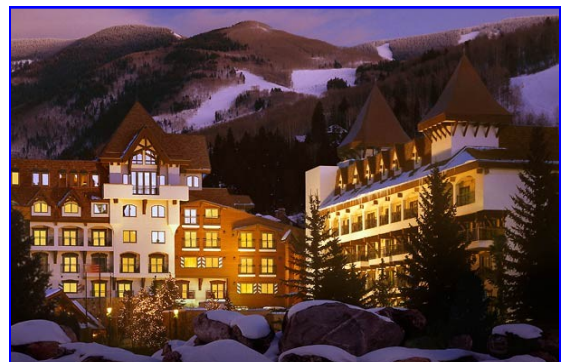

**Marriott  
Vail, Colorado**

**Rocky Mountain Metals, Inc. is the proud supplier of hollow metal doors, frames and/or windows for these projects**

**Libraries - Serenity and design**

We are proud of the trust we have been shown and the opportunity we have been given to be part of the more prestigious libraries in the country. These are buildings where design and the feel of serenity are top priorities and it is certainly prestigious for a hollow metal company like Rocky Mountain Metals to support this.

JFK Library  
Lied Library  
TCU Mary Couts Burnett Library

Boston, MA  
Las Vegas, NV  
Fort Worth, TX

**JFK Library  
Boston, MA**



**Casinos - Money, money, money...**

Our base in Las Vegas has provided us with ample opportunities to supply products to some of the most prestigious casinos in the world. Our products have proven to provide the right level of security and aesthetics to cater to this demanding market.



**Caesar's Palace  
Las Vegas, NV**

**The Orleans Hotel and Casino  
Las Vegas, NV**

- |                              |                  |
|------------------------------|------------------|
| Bally's Casino               | Las Vegas, NV    |
| Boardwalk Casino             | Las Vegas, NV    |
| Caesar's Palace              | Las Vegas, NV    |
| MGM Grand – Theatre          | Las Vegas, NV    |
| The Orleans Hotel and Casino | Las Vegas, NV    |
| Stratosphere                 | Las Vegas, NV    |
| Sunrise Casino               | Las Vegas, NV    |
| Treasure Island Casino       | Las Vegas, NV    |
| Winstar Hotel and Casino     | Thackerville, OK |



# Hollow Metal Doors

## A full line of Hollow Metal Doors

- 1100 Doors with Polystyrene Core
- 1200 Steel Stiffened Doors
- 1300 Temperature Rise Doors
- 1400 Doors for Tornado Solutions
- 1500 Lead lined Doors
- 1600 Dutch Doors

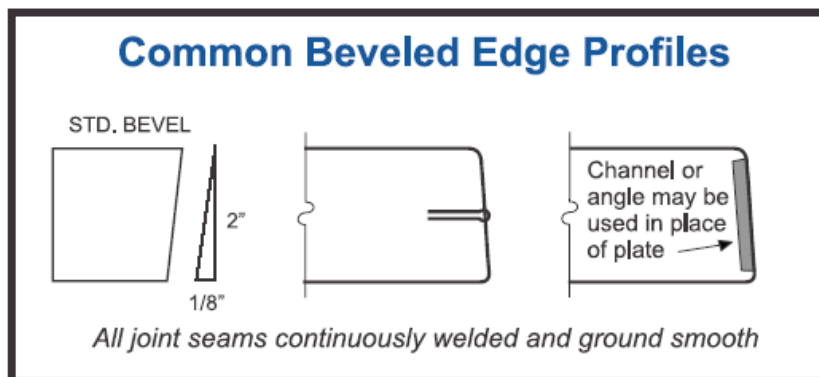
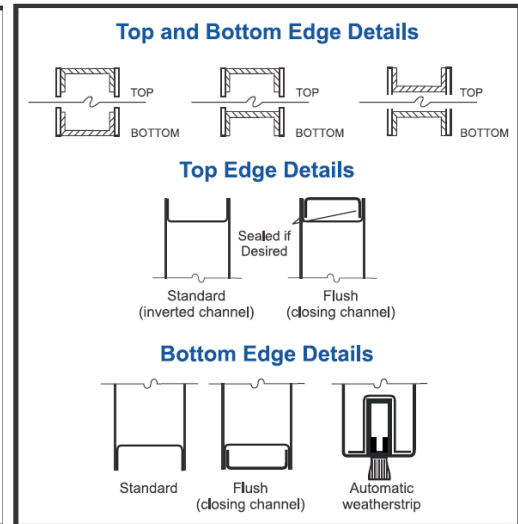
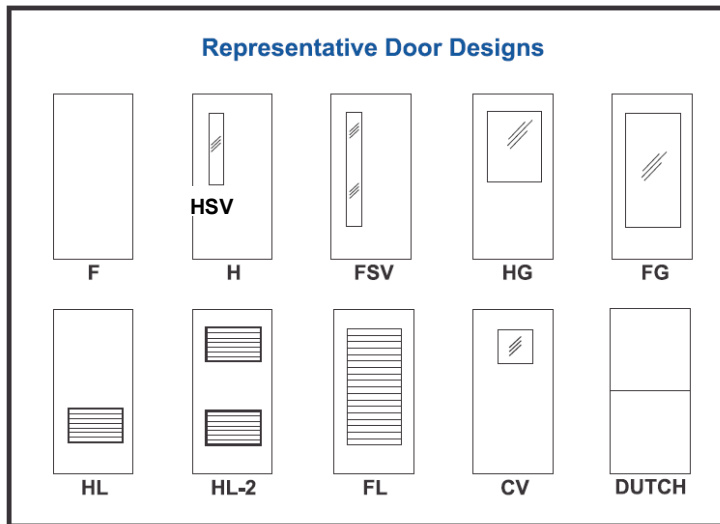

**Manufacturing Tolerances**

Manufacturing tolerances shall be maintained within the following limits for Doors

Width +/- 1/32 in. (.08mm)  
 Height +/- 3/64 in. (1.2mm)  
 Thickness +/- 1/16 in. (1.6mm)  
 Hardware cutout dimensions/Template dimensions +0.015", -0"  
 Hardware location +/- 1/32 in. (.08mm)

# Door Details - Typical Hardware Preparations

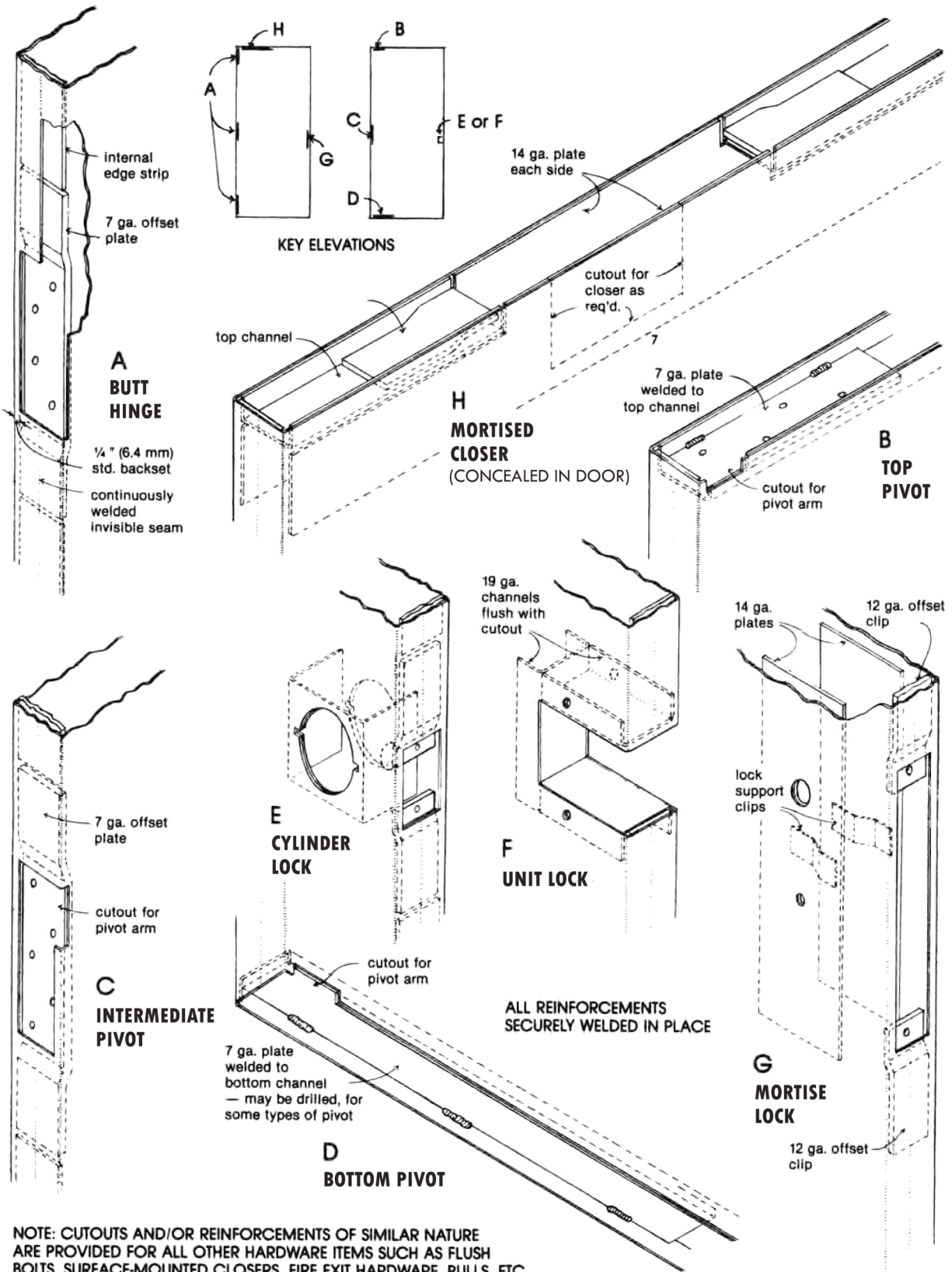

## 1100 Hollow Metal Door with Polystyrene Core/Fire Rated

Face Material	Galvannealed A40 or A60 ASTM-A-653
Face thickness	12, 14, 16 and 18 Ga.
Construction	Rigid polystyrene core bonded to both face sheets
Door thickness	1 3/4" Standard
Hardware Locations	Any specified locations
Reinforcements	7 Ga. 1 1/4" x 10" joggled hinge reinforcement, drilled and tapped 12 Ga. mortise hardware tabs, drilled and tapped 14 Ga. surface hardware and trim reinforcement
Edge reinforcement	Both edges reinforced with 16 Ga. full length channels spot welded to the face sheets
Vertical edges	Fully welded with no visible seam (for doors up to 4' wide and 8' height)
Glazing/ Louvers	Glazing stops to be set for 1/4" glass (3/8" space) unless otherwise requested. Note: Glass should be cut 1/4" less than door cut out. Exposed glass opening is 1 5/16" less than cutout dimensions. Louver size is actual size of door cutout
Handing	Doors are handed
Appearance	Faces and edges free of defects, warp and buckle
Finish	Thoroughly cleaned and coated with a rust inhibiting primer meeting requirements as per ANSI/SDI A250.10
Fire Rated	3 ft. wide, 7ft. High doors can be manufactured fire rated up to 3 hours. Hardware can be mortise or cylindrical locks. Mortise or rim type fire exit hardware. Surface mounted vertical rod type fire exit hardware.

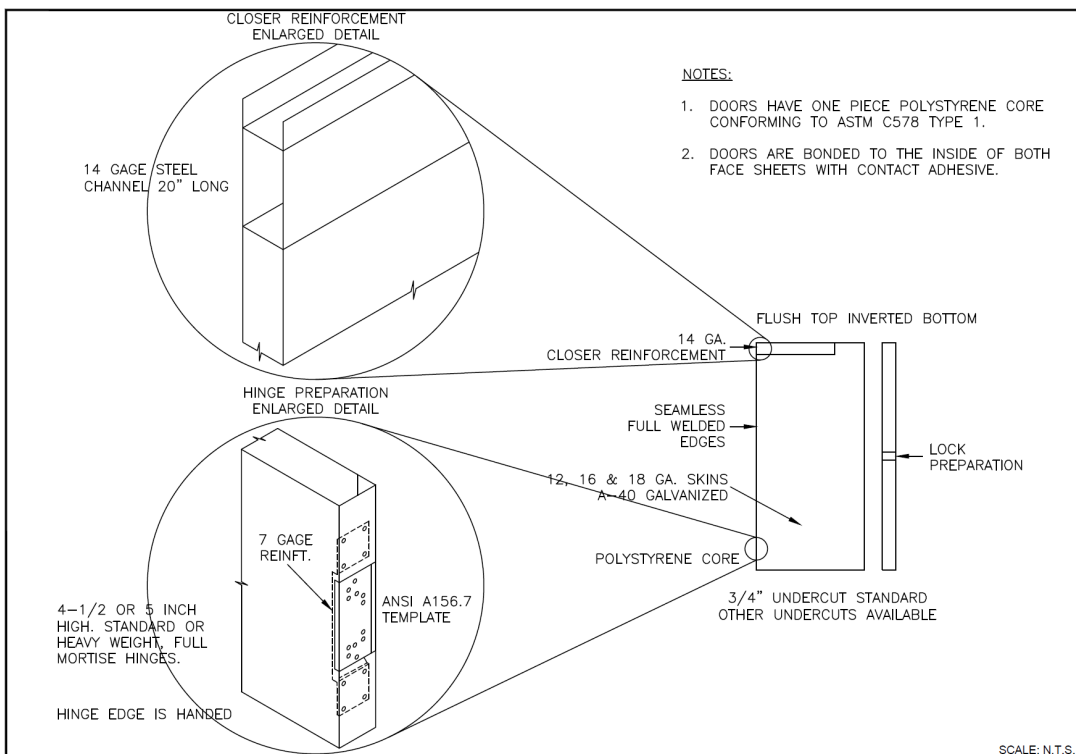

## 1200 Steel Stiffened Door / 1500 Lead Lined Door

Face Material	Galvannealed A40 or A60 ASTM-A-653
Face thickness	12, 14, 16 and 18 Ga.
Lead Lining	Center door lead lining (optional)
Construction	Hollow metal with vertical steel stiffeners (ribs). Space between ribs Insulated with glass wool insulation
Door thickness	1 3/4" Standard
Hardware Locations	Any specified location
Reinforcements	7 Ga. 1 1/4" x 10" joggled hinge reinforcement, drilled and tapped 12 Ga. mortise hardware tabs, drilled and tapped 14 Ga. surface hardware and trim reinforcement
Edge reinforcement	Vertical and horizontal edges reinforced with 16 Ga. (min) full length channels spot welded to the face sheets
Vertical edges	Fully welded with no visible seam (for doors up to 10' height and 4' width)
Glazing/ Louvers	Glazing stops to be set for 1/4" glass (3/8" space) unless other wise requested. Note: Glass should be cut 1/4" less than door cut out. Exposed glass opening is 1 5/16" less than cutout dimensions. Louver size is actual size of door cutout
Handing	Doors are handed
Appearance	Faces and edges free of defects, warp and buckle
Finish	Thoroughly cleaned and coated with a rust inhibiting primer meeting requirements as per ANSI/SDI A250.10
Options	UL Labeling requirements as specified

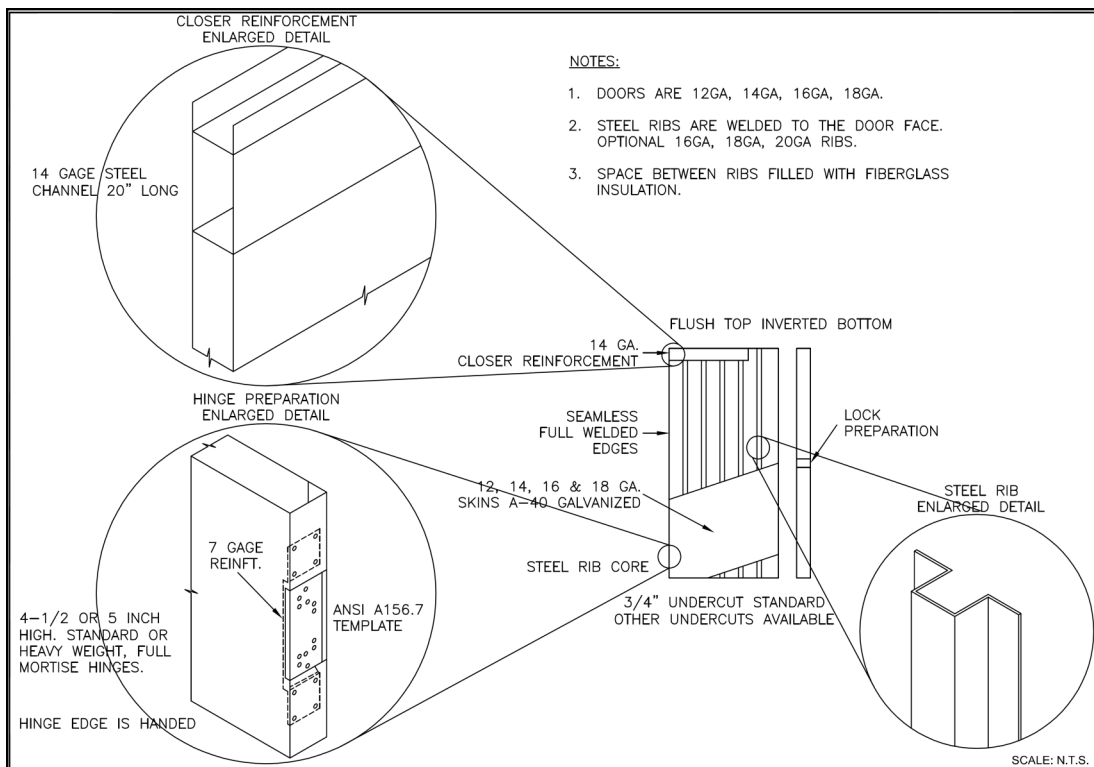

# 1300 Temperature Rise Door

Face Material	Galvannealed A40 or A60 ASTM-A-653
Face thickness	12, 14, 16 and 18 Ga.
Construction	Rigid mineral board core bonded to both face sheets
Door thickness	1 3/4" Standard
Hardware Location	Any specified locations
Reinforcements	7 Ga. 1 1/4" x 10" joggled hinge reinforcement, drilled and tapped 12 Ga. mortise hardware tabs, drilled and tapped 14 Ga. surface hardware and trim reinforcement
Edge reinforcement	Vertical and horizontal edges reinforced with 16 Ga. full length channels spot welded to the face sheets
Vertical edges	Fully welded with no visible seam (for doors up to 10' height and 4' width)
Glazing	Glazing stops to be set for 1/4" glass (3/8" space) unless other wise requested. Note: Glass should be cut 1/4" less than door cut out. Exposed glass opening is 1 5/16" less than cutout dimensions. Glass area up to 100 sq. inches.
Handing	Doors are handed
Appearance	Faces and edges free of defects, warp and buckle
Finish	Thoroughly cleaned and coated with a rust inhibiting primer meeting requirements as per ANSI/SDI A250.10
Temperature Options	60-180 min. Labels available for 450 degree and 250 degree temp. UL Labeling requirements as specified

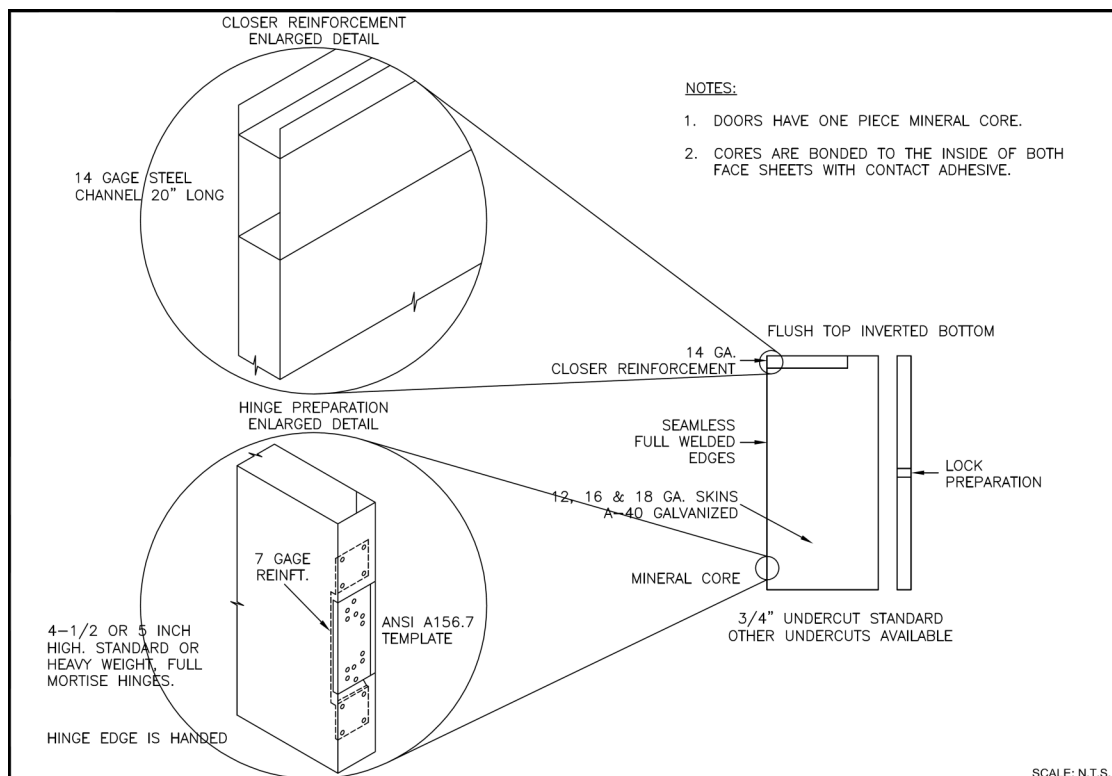

## 1600 Dutch Doors

Face Material	Galvannealed A40 or A60 ASTM-A-653
Face thickness	12, 14, 16 and 18 Ga.
Construction	Can be manufactured as a Polystyrene Core (1100 door) or Steel Stiffened Door (1200 door)
Door thickness	1 3/4" Standard
Hardware Locations	Any specified locations
Reinforcements	7 Ga. 1 1/4" x 10" joggled hinge reinforcement, drilled and tapped 12 Ga. mortise hardware tabs, drilled and tapped 14 Ga. surface hardware and trim reinforcement
Edge reinforcement	Both edges reinforced with 16 Ga. full length channels spot welded to the face sheets
Vertical edges	Fully welded with no visible seam (for doors up to 4' wide and 8' high)
Glazing/ Louvers	Glazing stops to be set for 1/4" glass (3/8" space) unless otherwise requested. Note: Glass should be cut 1/4" less than door cut out. Exposed glass opening is 1 5/16" less than cutout dimensions. Louver size is actual size of door cutout
Handing	Doors are handed
Appearance	Faces and edges free of defects, warp and buckle
Finish	Thoroughly cleaned and coated with a rust inhibiting primer meeting requirements as per ANSI/SDI A250.10
Options	Shelf available as specified

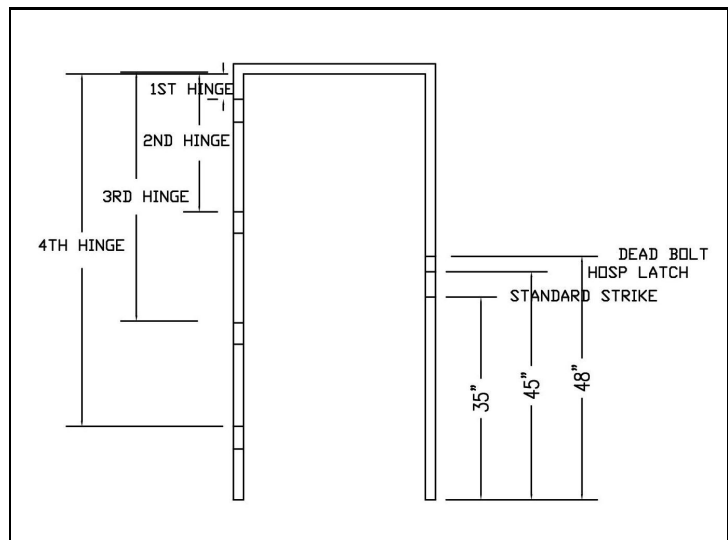
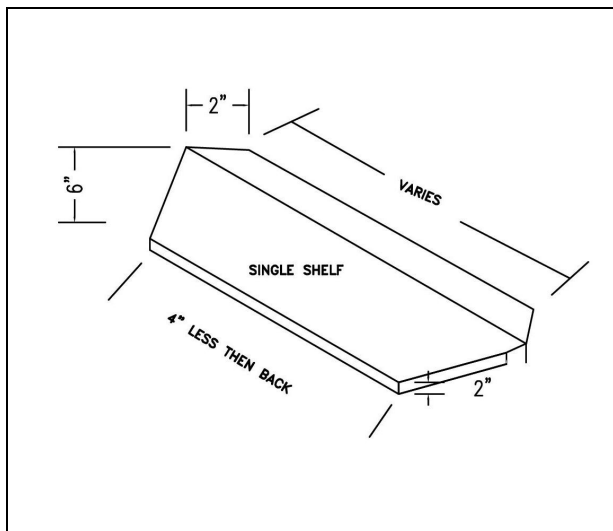



1600 Dutch Doors

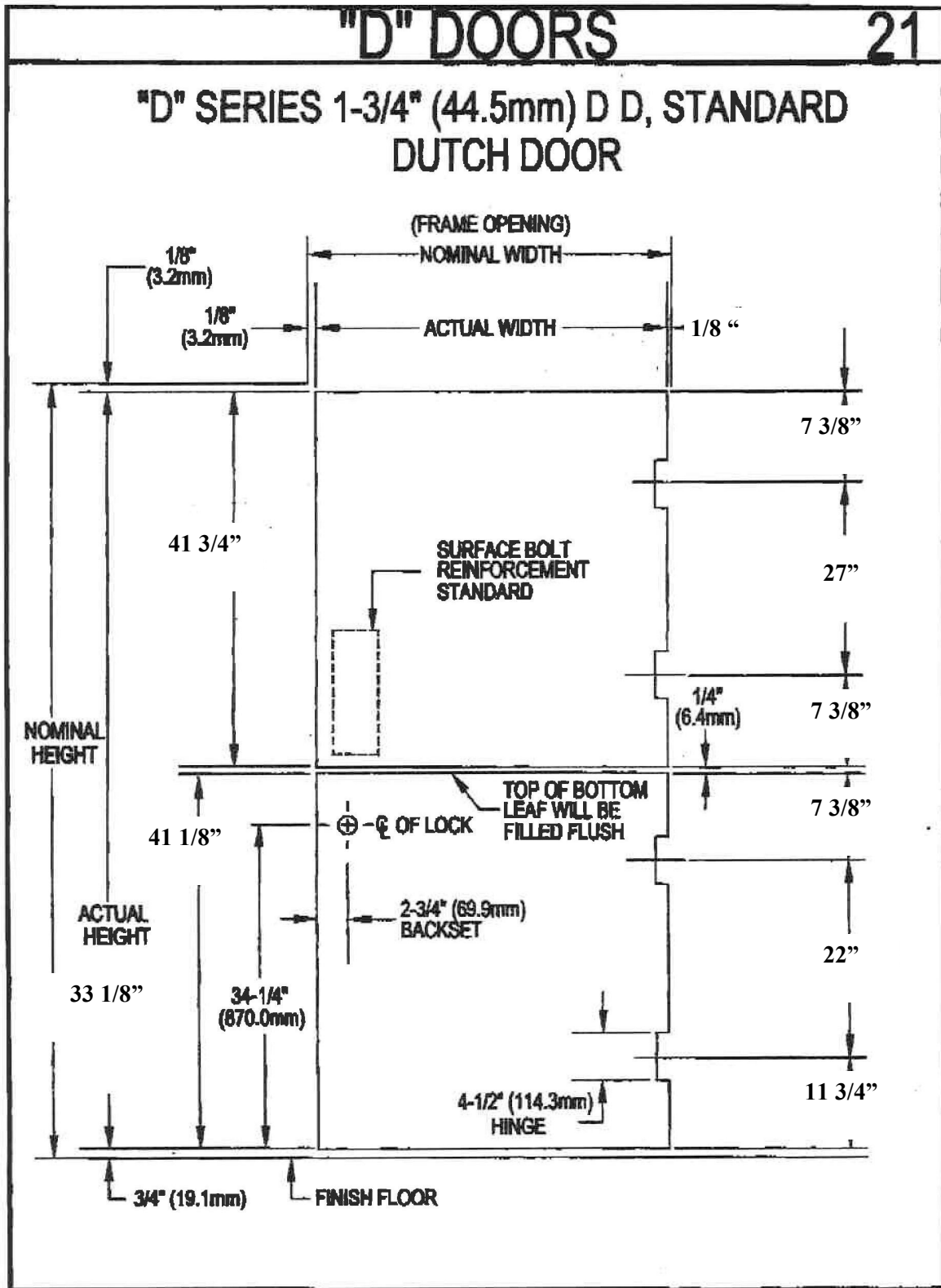

# Hollow Metal Frames

## A full line of standard and custom frames:

- Standard door frames, fully or face welded, optional with Hospital stops
- Window frames
- Sidelights
- Standard, window and sidelight frames can be supplied lead lined
- Knock down (KD) frames for welding
- Dry wall knock down (KD frames)
- Custom frames
- Pocket Frames
- Double Egress Frames

### Manufacturing Tolerances for Frames

Frames for single door or pair of doors:

Width, measured between rabbets at the head; nominal opening width  $+1/18'' - 1/32''$

Height (total length of jamb rabbet): nominal opening height  $\pm 3/64''$

Frames overlapping walls to have throat dimension  $1/8''$  greater than dimensioned wall thickness to accommodate irregularities in wall construction.

### Standard frame anchors

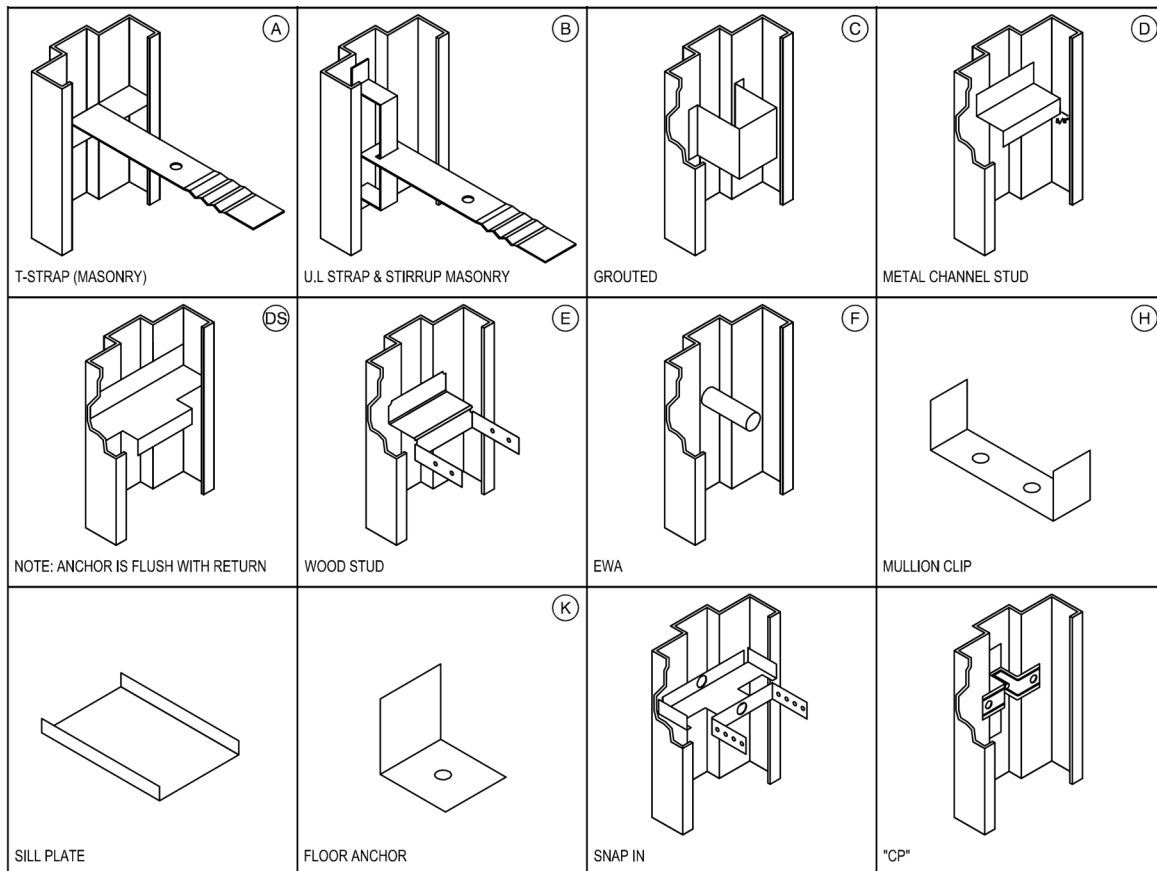

# Hollow Metal Frames

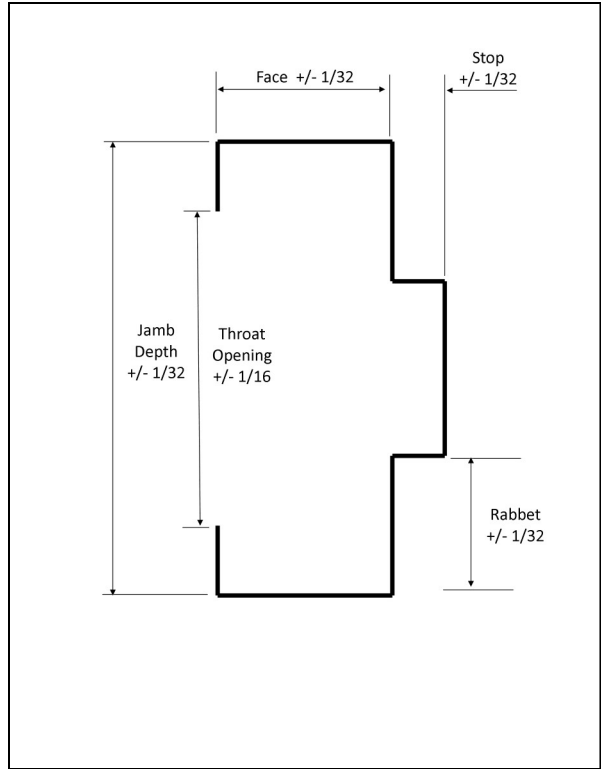

## Standard frame sections

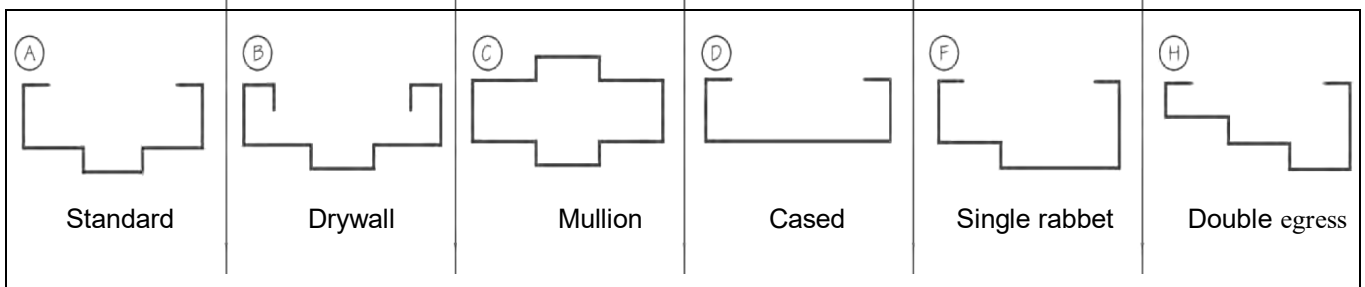

## Standard frame elevations

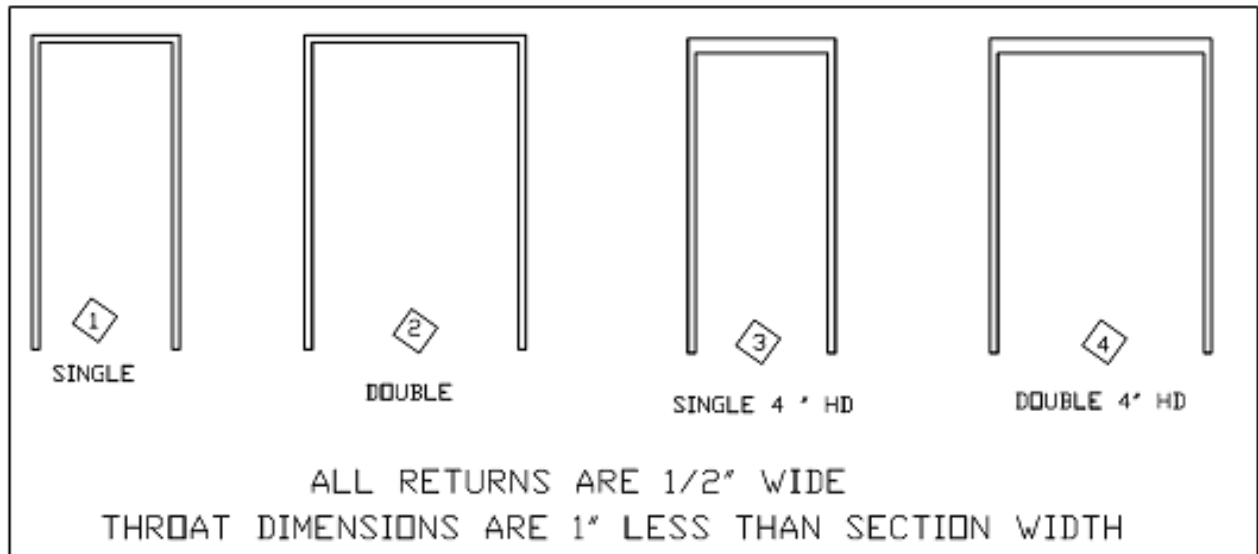

## Welded Frames

Material	Galvannealed A40 ASTM-A-653
Thickness	12, 14 and 16 Ga.
Construction	Mitered and welded face and back alternatively welded face only
Appearance	Square, true and free of defects, warp and buckle
Hardware	7 Ga. 1 1/4" x 10" joggled hinge reinforcement, drilled and tapped. 12 Ga hardware reinforcements. Backwelded for additional strength. Also mortised, enforced, drilled and tapped at the factory for hardware in accordance with approved schedule and templates provided by hardware contractor. Strike jambs prepared for three rubber silencers, unless otherwise specified
Anchors	Anchors as specified. For standard frames, four 16 Ga. weld in sill anchors per jamb
Guards	Dust covers on all frames. Mortar guards on frames for masonry walls.
Spreaders	Temporary spreader bars welded to the bottom of all three sided frames. To be removed before installation
Marking	Embossed with opening numbers above the middle hinge. In the jamb for continuous hinge frames
Finish	Thoroughly cleaned and coated with a rust inhibiting primer meeting requirements as per ANSI/SDI A250.10

### Typical Hardware Preparations

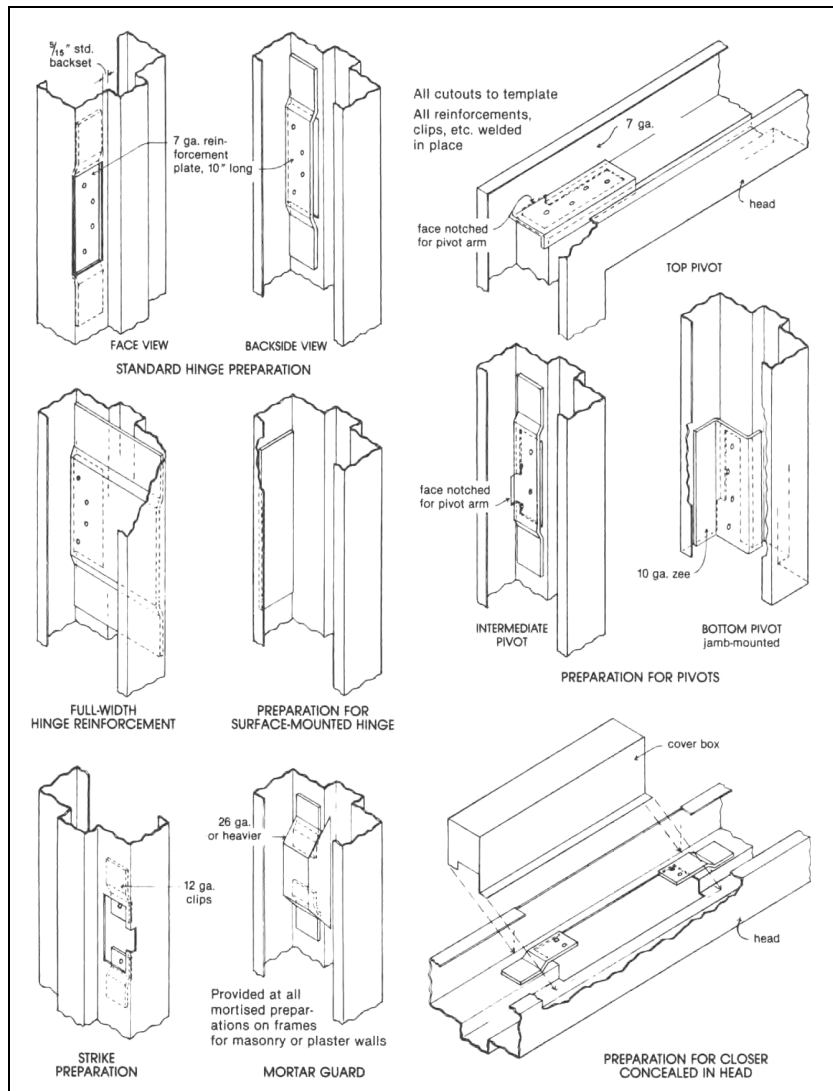

## Knockdown (KD) Frames

The frames provided by Rocky Mountain Metals, Inc. are of two types. They are either made to be welded or to be installed in a pre-installed or existing drywall wall.

Material	Galvannealed A40 ASTM-A-653
Thickness	12, 14 and 16 Ga.
Construction	Mitered with self aligning tabs and slots for securely locking the corners
Appearance	Free of defects, warp and buckle
Hardware	7 Ga. 1 1/4" x 10" joggled hinge reinforcement, drilled and tapped. Back welded for additional strength. Also mortised, enforced, drilled and tapped at the factory for hardware in accordance with approved schedule and templates provided by Hardware Contractor. Strike jambs prepared for three rubber silencers, unless otherwise specified
Anchors	Anchors as specified. For standard frames, four 16 Ga. weld in sill anchors per jamb
Guards	Dust covers on all frames. Mortar guards on frames for masonry walls. KD frames for drywall walls supplied with one compression anchor per jamb
Marking	Embossed with opening numbers above the middle hinge. In the head for continuous hinge frames. Temporary marking of heads and jamb to ensure correct pairing
Finish	Thoroughly cleaned and coated with a rust inhibiting primer meeting requirements as per ANSI/SDI A250.10

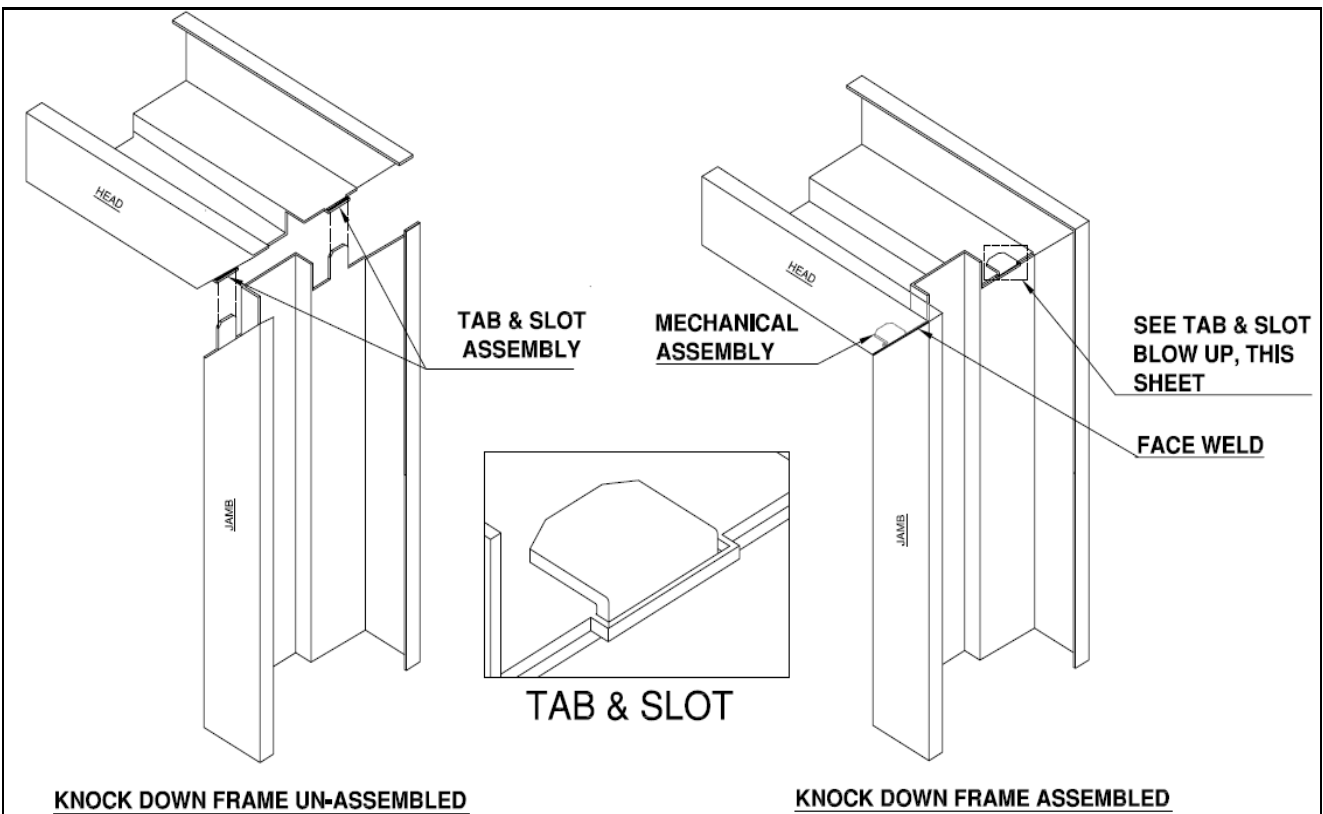

# Pocket Frames

Material	Galvannealed A40 ASTM-A-653
Thickness	12, 14 and 16 Ga.
Construction	Mitered and welded face and back alternatively welded face only
Appearance	Square, true and free of defects, warp and buckle
Hardware	Optional prep to accept hardware as specified
Anchors	Anchors to meet any wall construction
Strike	Any specified location
Jamb Width	6" Standard
Guards	Dust covers on all frames. Mortar guards on frames for masonry walls.
Spreaders	Temporary spreader bars welded to the bottom of all three sided frames. To be removed before installation
Marking	Embossed with opening numbers above the middle hinge. In the jamb for continuous hinge frames
Finish	Thoroughly cleaned and coated with a rust inhibiting primer meeting requirements as per ANSI/SDI A250.10
NOTE	Sliding and tracking not provided

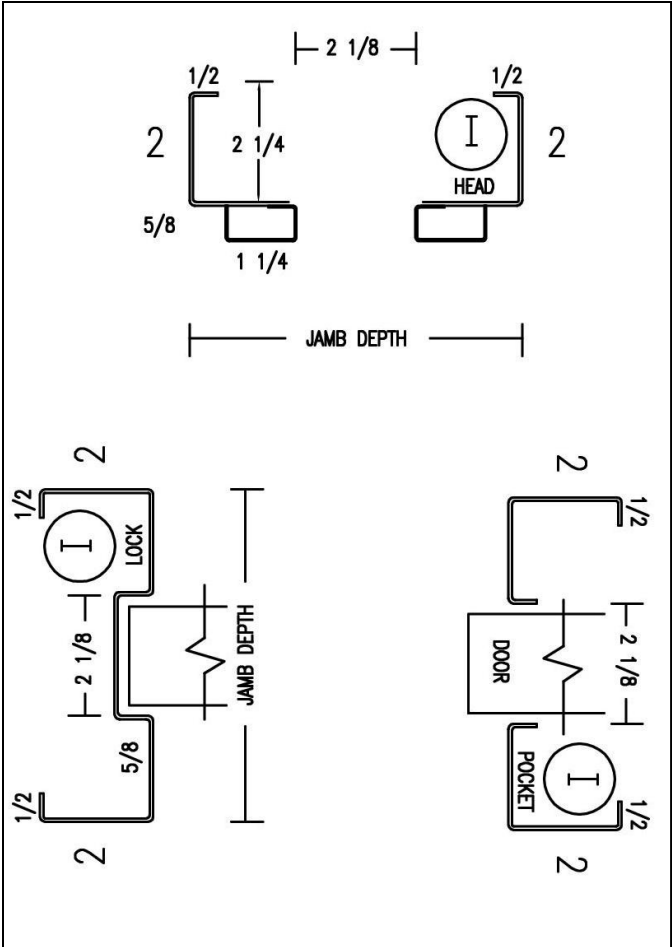
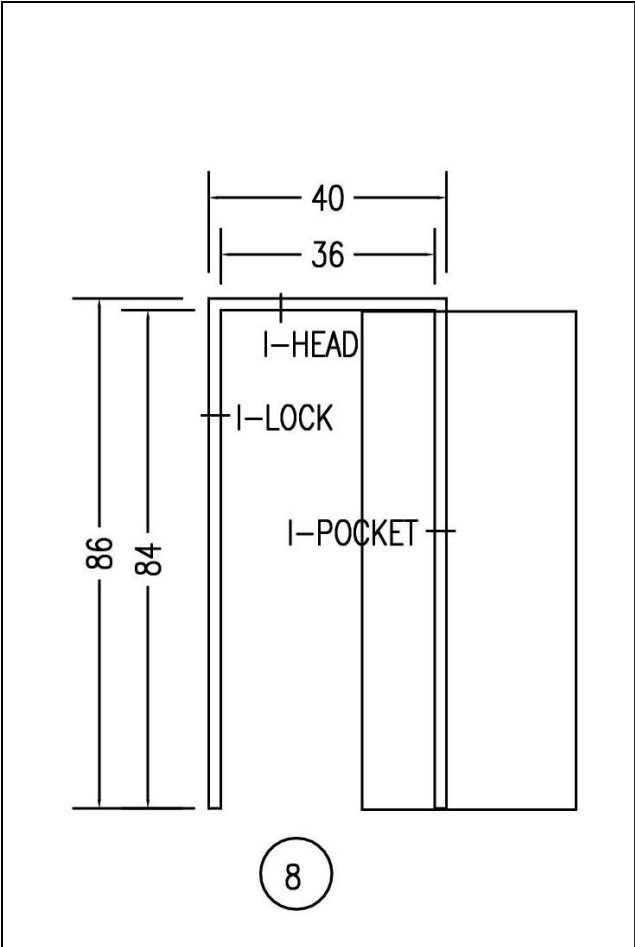

## Custom Frames

Rocky Mountain Metals, Inc. has been in business since 1988 and our entire focus is on hollow metal manufacturing. Our plant is fully equipped with modern equipment to cater to your Standard and Custom Hollow Metal needs.

We have the ability to produce complex custom configurations to meet a wide variety of individual needs. Our strong focus is on quick quoting, quality, cost efficiency and quick shipping. In addition to your specific needs and specifications, our products are built by elements according to the NAAMM Standard HMMA 860, 861 and 862. We are a member of NAAMM and we manufacture products in accordance with the Steel Door Institute standards.

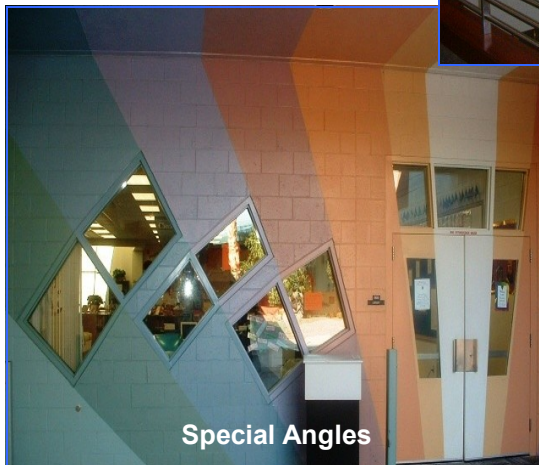

## Tornado Resistant Openings



Rocky Mountain Metals, Inc. introduces Openings Solutions classified to FEMA P-361 (2015) and certified to ICC 500 (2014). These openings are tested as complete assemblies including doors, frames and hardware as required by the International Building Code for use in tornado shelters in Group E occupancies. This includes among other applications new construction at K-12 schools and extends to critical emergency operation facilities.

The offerings consists of openings of up to 8 ft. in width and 9 ft. in height for double doors and 4 ft. in width and 9 ft. in height for single doors and is also extended to shutters (openings with four sided frames).

### **Single Doors and Shutters**

Min dimensions	width	2 ft 6 inches
	height	4 ft
Max dimensions	width	4 ft
	height	9 ft
In and out swing		

### **Double doors**

Min dimensions	width	6 ft
	height	6 ft 8 inches
Max dimensions	width	8 ft
	height	9 ft
Out swing only		



## 1400 FEMA Frame and Shutter Frame Details for Tornado Resistant Openings

Material	Galvannealed A40 ASTM-A-653
Thickness	14 Ga. Galvannealed
Dimensions	2" jambs and 2" or 4" heads as specified
Construction	Mitered and welded face and back
Appearance	Square, true and free of defects, warp and buckle
Reinforcements	4 pcs 7 Ga. 1 1/4" x 10" joggled hinge reinforcement, drilled and tapped. Back welded for additional strength Strike and bolt preps 12 Ga. x 12" long, spot and MIG welded Strike jambs prepared for three rubber silencers, unless Otherwise specified
Hardware Locations	Any specified locations
Guards	Dust covers on all frames. Mortar guards on frames for masonry walls
Wall Anchors	Below 7' in Height - 4 anchors 7' and above in Height - 5 anchors
Head Anchors	5' and above in Width - 2 anchors
Bolts	As per specified by RMMI
Spreaders	Temporary spreader bars welded to the bottom of all three sided frames. To be removed before installation
Marking	Embossed with opening numbers above the middle hinge. In the jamb for continuous hinge frames
Finish	Thoroughly cleaned and coated with a rust inhibiting primer meeting requirements as per ANSI/SDI A250 10
Options	UL labeling requirements as specified
Shutter Frame Sizes	Min: 2' 6" x 4'                      Max: 4' x 9'
Door Frame Sizes	Min: 2' 6" x 4'                      Max: 8' x 9'

Shutter Frames are manufactured as four sided frames

# 1400 FEMA Frames for Tornado Resistant Openings

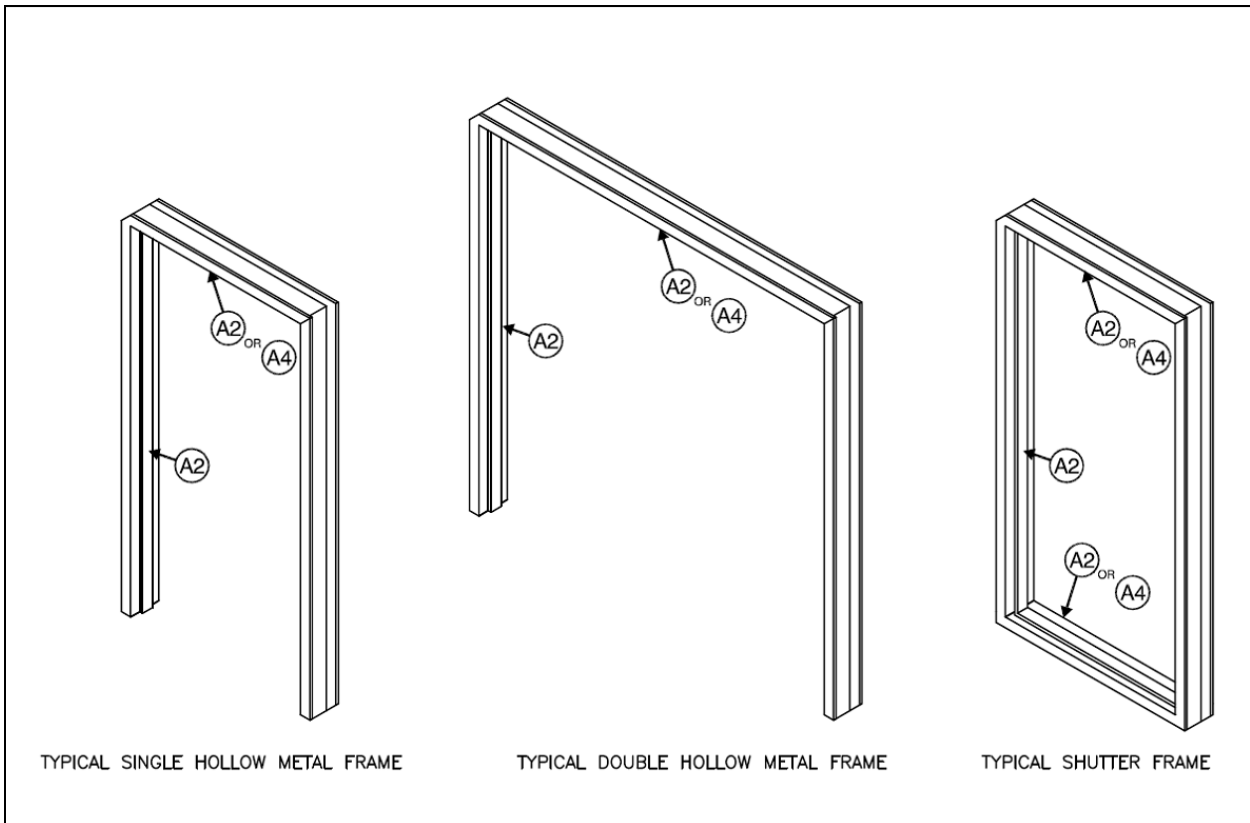
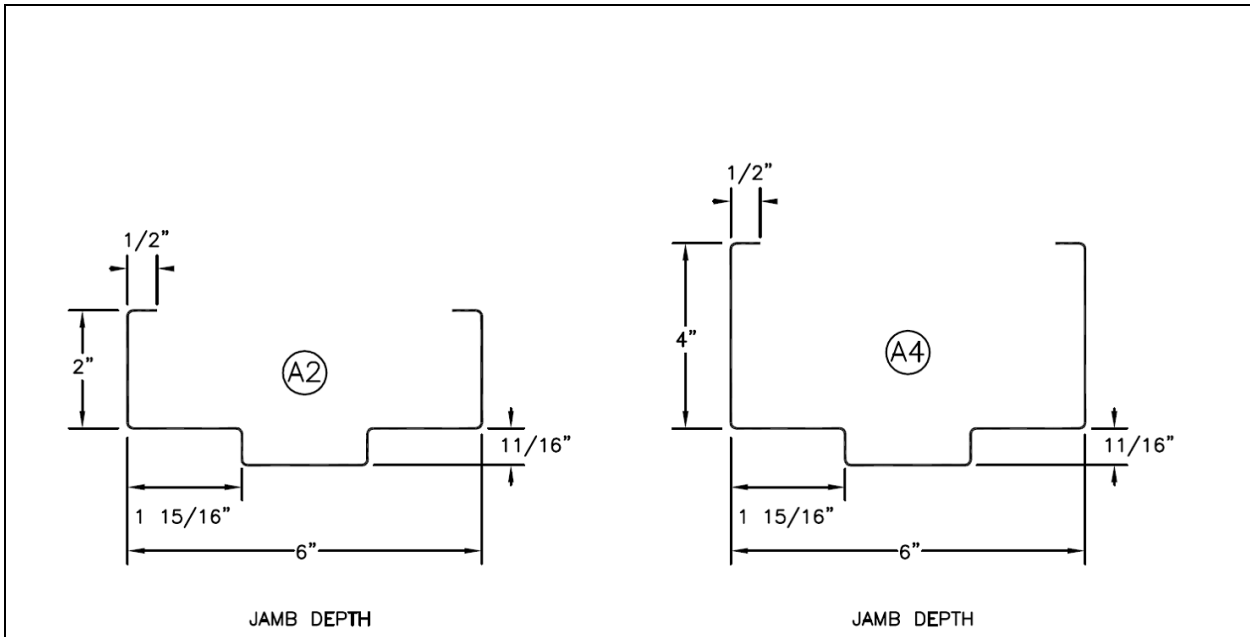

## 1400 FEMA Door/Shutter for Tornado Resistant Openings

Face Material	Galvannealed A40 or ASTM-A-653
Face thickness	14 Ga.
Construction	Hollow metal with 18 Ga. vertical steel stiffeners (ribs). Space insulated with glass wool insulation between ribs. Flush construction
Door thickness	1 3/4" Standard
Hardware Locations	Per Project Requirements
Reinforcements	7 Ga. 1 1/4" x 10" joggled hinge reinforcement, drilled and tapped 12 Ga. mortise hardware tabs, drilled and tapped 12 Ga. surface hardware and trim reinforcement
Edge reinforcement	Horizontal and vertical edges reinforced with 12 Ga. (min) full length channels spot welded to the face sheets
Vertical edges	Fully welded with no visible seam
Handing	Doors are handed
Appearance	Faces and edges free of defects, warp and buckle
Finish	Thoroughly cleaned and coated with a rust inhibiting primer meeting requirements as per ANSI/SDI A250.10
Options	UL Labeling requirements as specified

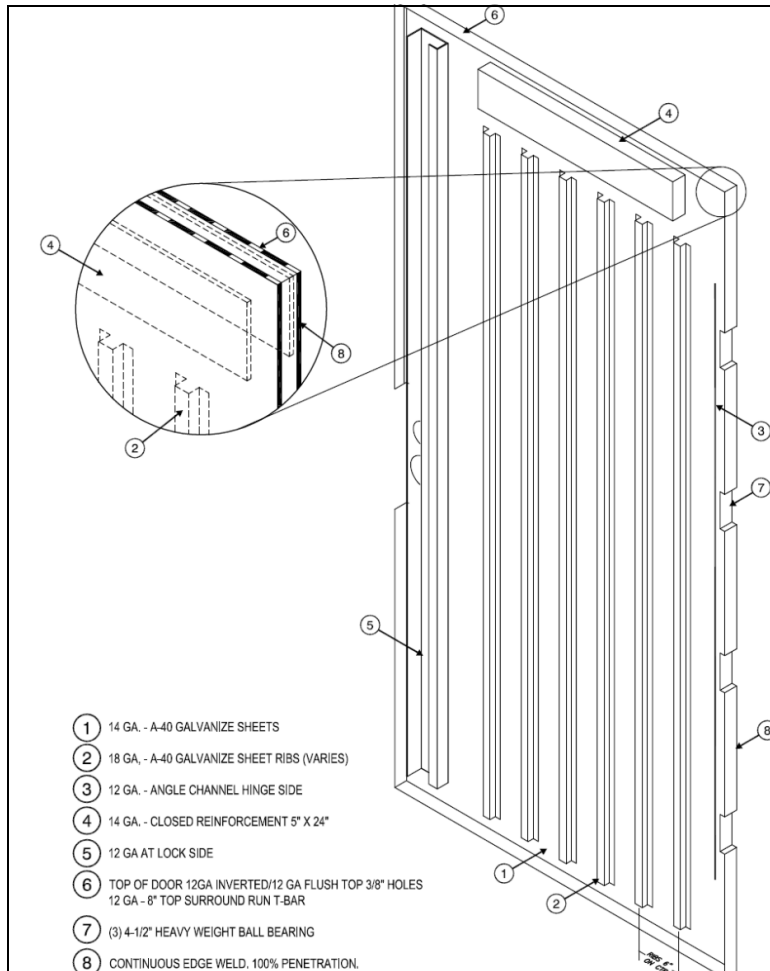

## Leadership in Energy and Environmental Design (LEED)

LEED – The Leadership in Energy and Environmental Design Green Building System is the nationally accepted rating system for the design, construction and operation of sustainable and energy efficient buildings. The LEED Certification promotes a complete building system and focuses on five key areas of human and environmental health:

- Sustainable site development
- Water savings
- Energy efficiency
- Materials selection
- Indoor environmental quality

All products from Rocky Mountain Metals, Inc. qualify for LEED Credits as per below:

Full credit for recycled content MR.4.1 and 4.2 as Doors as well as Frames from Rocky Mountain Metals, Inc. contain more than 25% recycled material as per the LEED Definitions (100% of Post Consumer and 50% of Pre Consumer Recycled Content).

For further information about the requirements see below:

Credit	Requirement
<b>Recycled Content MR 4.1</b>	Use material with recycled content such that the sum of the post-consumer recycled content plus 50% of the pre-consumer content constitutes at least 10% of the total values of the material in the project
<b>Recycled Content MR 4.2</b>	Use material with recycled content such that the sum of the post-consumer recycled content plus 50% of the pre-consumer recycled content constitutes an additional 10% beyond MR 4.1 Credit (total 20%) based on cost of the total values of the material in the project
<b>Regional Materials MR 5.1</b>	Use a minimum of 20% of the combined value of construction and Division 12 materials and products that are manufactured (final assembly of components) within a radius of 500 miles.

Definitions:

*Post-consumer recycled content* – Waste material generated by households or by commercial, industrial or institutional facilities in their role as end-users of the product, which can no longer be used for its intended purposes.

*Pre-consumer (post-industrial) recycled content* – scraps left over during industrial or manufacturing processes, which are subsequently reused.

# Contact Information

You can reach us at Rocky Mountain Metals, Inc.

Phone: 575.445.2756      Fax: 575.445.2804

## Email

info@rockymountainmetals.com  
sales@rockymountainmetals.com

## Production / GM

Ron Gonzales      rgonzales@rockymountainmetals.com

## Sales and Estimating

Brittan Buchanan      bbuchanan@rockymountainmetals.com  
Jae Leavitt      jleavitt@rockymountainmetals.com

## Delivery and Billing

Melanie Wahl      mwahl@rockymountainmetals.com

## Engineering

Larry Whitish      lwhitish@rockymountainmetals.com

You can also find us online at

[RockyMountainMetals.com](http://RockyMountainMetals.com)



**Questions?  
Contact Us**  
1-575-445-2756



## CERTIFICATIONS



Read more at <http://industries.ul.com/building-materials>

### BUY AMERICAN ACT

All Rocky Mountain Metals, Inc. standard and custom hollow metal frames and doors are manufactured in their New Mexico manufacturing plant from materials produced substantially in the United States and as such, meet the requirements of 41 U.S.C 10, commonly known as the Buy-American Act. In addition, all Rocky Mountain Metals, Inc. products meet the “Made in USA” standards set forth by the Federal Trade Commission (FTC) Act and Enforcement Policy Statement.



**MEMBER**

### **Rocky Mountain Metals, Inc.**

140 Coal St. · P.O. Box 1101 · Raton, New Mexico 87740

Phone: 575.445.2756 · Fax: 575.445.2804

[info@rockymountainmetals.com](mailto:info@rockymountainmetals.com)

[www.rockymountainmetals.com](http://www.rockymountainmetals.com)